

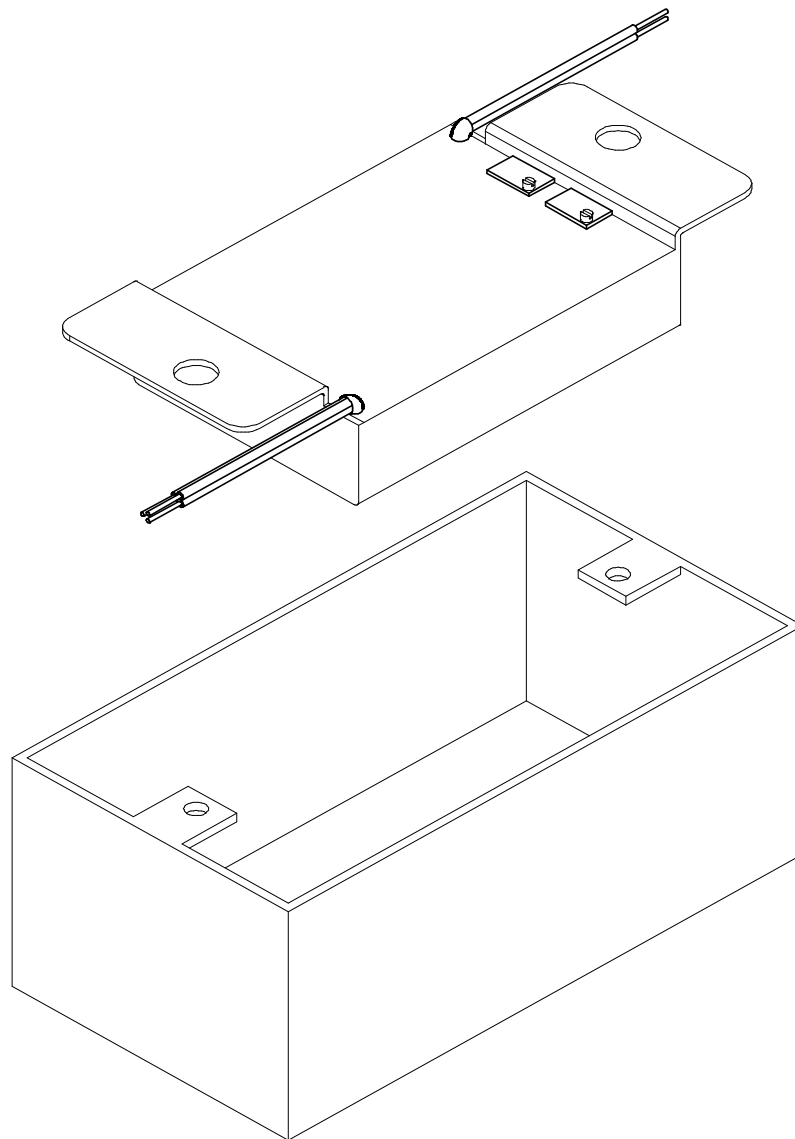

**TT801/TT807 Temptran™  
2-wire Temperature Transmitter and Housing  
Installation and Operating Instructions**



## Description

Model TT801/807 is a 2-wire temperature transmitter for RTD (Resistance Temperature Detector) thermometers. The TT801 uses a 100 ohm platinum RTD and the TT807 uses a 1000 ohm platinum RTD. The Temptran™ converts the RTD's signal into a 4 to 20 mA current. The current changes according to the range in which the Temptran is calibrated: 4 mA at the lowest temperature of the range, rising to 20 mA at the top of the range. The leads that supply power also carry the current signal. Request Minco Application Aid 15 for more general information on transmitters.

## Specifications

<b>Sensing Element:</b>	100 ohm platinum RTD, 0.00385 ohm/ohm/°C TCR, (TT801) 2 or 3 wire. 1000 ohm platinum RTD, 0.00375 ohm/ohm/°C TCR, (TT807) 2 or 3 wire
<b>Output:</b>	4 to 20 mA DC over specified range.
<b>Calibrated Accuracy:</b>	+/- 0.1% of span.
<b>Transmitter Linearity:</b>	+/- 0.1% of span.
<b>Adjustments:</b>	Zero and Span; +/- 5% of Span, non-interacting.
<b>Operating Environment:</b>	-40 to 185 °F (-40 to 85 °C).
<b>Storage Environment:</b>	-67 to 212 °F (-55 to 100 °C).
<b>Ambient Temperature Effects:</b>	+/- 0.01% Span/°F (+/- 0.018% Span/°C). +/- 0.014% of Span/°F (+/- 0.25% of Span/°C) for Spans < 100°F
<b>Warm-up Drift:</b>	+/- 0.1% of span max., assuming Vsupply = 24 VDC and Rloop = 250 ohms. Stable within 15 minutes.
<b>Supply Voltage:</b>	8.5 to 35 volts DC with no load.
<b>Input Voltage Effect:</b>	+/- 0.001% of span per volt.
<b>Maximum Load Resistance:</b>	The maximum allowable resistance of the signal-carrying loop is given by this formula: $R_{loop\ max} = (V_{supply} - 8.5) / .02\ amps$
<b>System Integration:</b>	Output "High" (22-25mA) with sensor open. Output "Low" (3.3-3.7mA) with sensor shorted.
<b>Maximum Output Current:</b>	28 mA.
<b>Lead Wire Compensation:</b>	(3-wire RTD); +/- 0.06% of span per ohm, up to 25 ohms in each leg.
<b>Power Connections:</b>	Red (+), Black (-)
<b>Sensor Connections:</b>	Screw terminals, non-polar (connect either way).
<b>Physical:</b>	Epoxy-potted for moisture resistance.
<b>Weight:</b>	4.0 oz. (112 grams).

## Installation

Using wirenuts, connect the Temptran as shown below (Figure 1), observing the ± polarity of the current loop. Maximum DC supply voltage = 35 VDC. The RTD must be connected as shown or the transmitter will not function properly. Screw the Transmitter into a utility box near the RTD, in an area where the ambient temperature stays between -50 and 80 °C (-58 and 176 °F).

1. For 3 wire RTD version, connect the RTD's common-colored leads to the two White wires as shown below (Figure 1), then connect the remaining sensor lead to the black wire. If the sensor has only 2 leads, short the transmitter's white wires together and connect them to one wire of the sensor and black to the other wire. A 2-wire RTD is not polarity-sensitive.
2. Observing polarity, connect a DC source, not exceeding 35 Volts to the remaining two wires (Red, Black).

## Wiring Diagram

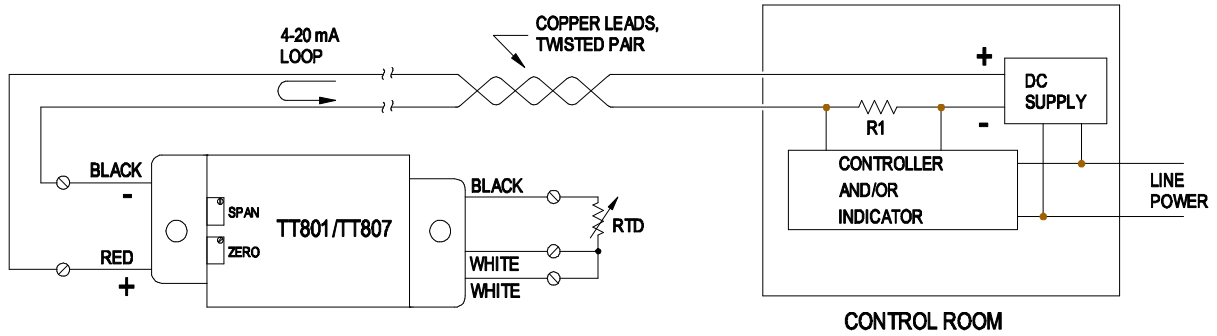

Figure 1

## Power Supply

DC power supply requirements are determined by the TT801/807 minimum voltage requirement and voltage drop across the load resistor and installation lead wires.

Example: The transmitter requires 8.5 Volts minimum. A typical 250 ohm load resistor drops 5.0 Volts @ 20 mA. Allowing a margin of 0.5 Volts for the supply permits 25 ohms of lead wire resistance for remote installation. Totaling these, we get the minimum power supply requirement of 14 VDC.

Using a 24 VDC power supply will take care of nearly all installations, though the TT801/807 will operate with as much as 35 VDC.

## How to Order:

TT801	Model Number: TT801 TT807
PD	Resistance thermometer type: RTD Temptran PA = 100 Ω Platinum (.00392) TT801 only PB = 100 Ω Platinum (.00391) TT801 only PD = 100 Ω Platinum (.00385) TT801 only PE = 100 Ω Platinum (.00385) TT801 only PF = 1000 Ω Platinum (.00385) TT807 only PW = 1000 Ω Platinum (.00375) TT807 only
1	4 to 20 mA DC Output
S	Temperature Range (4 mA Temp/20 mA Temp): EN = -20 to 140°F (-29 to 60°C) S = 0 to 100°F (-18 to 38°C) A = 20 to 120°F (-7 to 49°C) BI = 30 to 130°F (-1 to 54°C) KK = 30 to 180°F (-1 to 82°C) BN = 30 to 240°F (-1 to 116°C) N = 32 to 122°F (0 to 50°C) H = 40 to 90°F (4 to 32°C) M = -58 to 122°F (-50 to 50°C) C = 32 to 212°F (0 to 100°C) BW = 32 to 482°F (0 to 250°C) JW = 32 to 932°F (0 to 500°C) SX = Special range as defined on job order. Consult factory for current list of available ranges.
TT801PD1S ← Sample Part Number	

**Special OEM Transmitter Replacements (cross reference):**

TT801-B1, ( 30° to 240°F);	Order MINCO part #	TT801PD1BN
TT801-B2, ( -20 to 140°F);	Order MINCO part #	TT801PD1EN
TT801-B3, ( 32° to 122°F);	Order MINCO part #	TT801PD1N
TT807-B1, ( 30° to 240°F);	Order MINCO part #	TT807PW1BN
TT807-B2, ( -20 to 140°F);	Order MINCO part #	TT807PW1EN
TT807-B3, ( 32° to 122°F);	Order MINCO part #	TT807PW1N

**Dimensions:** All dimensions are in inches (millimeters)

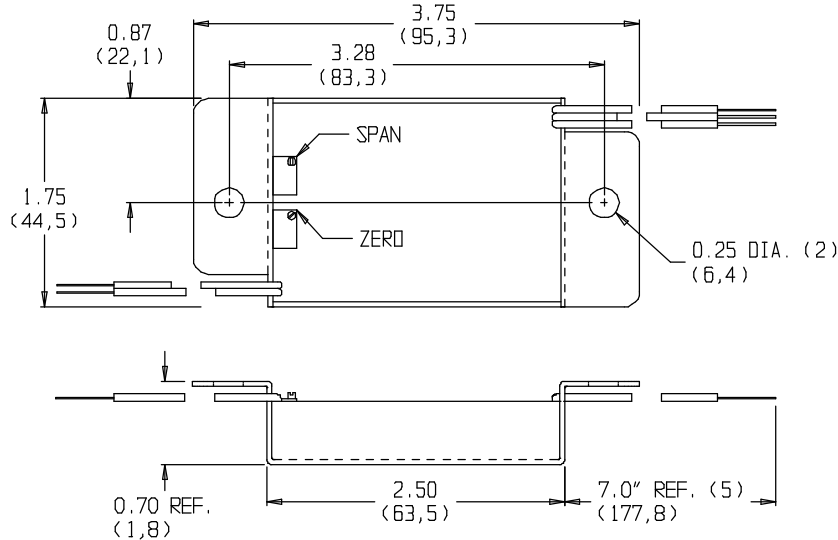

**Figure 3**

**Warranty**

Items returned within one year from the date of sale, transportation prepaid, which Minco Products, Inc. (The "Seller") reasonably determines to be faulty by reason of defective materials or faulty workmanship will be replaced or repaired at the Seller's discretion, free of charge. This remedy is to be the sole and exclusive remedy available to the buyer in the event of a breach by the Seller. Items that show evidence of mishandling or misapplication may be returned by the Seller at the customer's expense. Furthermore, the Seller is not to be held responsible for consequential damages caused by its product except as required under Minnesota Statutes, Section 336.1-719 (3). This warranty is expressly in lieu of any other expressed warranty or implied warranty of merchantability or fitness for a particular purpose, and of any other obligations or liability on the part of the Seller or its employees or agents.

**Minco (Main Office)**  
7300 Commerce Lane  
Minneapolis, MN  
55432  
USA  
Tel: 1.763.571.3121  
Fax: 1.763.571.0927

**Customer Service/  
Order Desk:**  
Tel: 1.763.571.3123  
Fax: 1.763.571.0942  
[custserv@minco.com](mailto:custserv@minco.com)  
[www.minco.com](http://www.minco.com)

**Minco S.A.**  
Usine et Service  
Commercial, Z.I.  
09310 Aston, France  
Tel: (33) 5 61 03 24 01  
Fax: (33) 5 61 03 24 09

**Minco EC**  
Hirzenstrasse 2  
CH-9244 Niederuzwil  
Switzerland  
Tel: (41) 71 952 79 89  
Fax: (41) 71 952 79 90

**ISO 9001:2000**  
F:\MOD\TT801\LIT\919MN.DOC  
Stock # 360-00081(-) 040405

**MINCO**  
A critical component of your success®  
[www.minco.com](http://www.minco.com)